



# RIG 803

1,800 hp AC Triple Mast Walking Drilling

## SUBSTRUCTURE

Swing Up - 3 piece Center Section with Rig Runner™ integrated walking System  
Floor Height: 31'-0" (9.45m)

Clear Height (beneath rotary beams): 27'-0" (8.23m)  
Rotary Capacity: 850,000 lbs (386 Metric Tons)  
Max Pipe Setback: 750,000 lbs (340 Metric Tons)

*Note: All floor heights are based on the substructure sitting on 6" Mats*

## MAST

142' (43.3m) Triple Mast – Designed to meet API 4F 4<sup>th</sup> Edition  
500 Ton Top Drive Integrated into Center Section for Transport  
Static Hook Load (12 Lines): 850,000 lbs (386 Metric Tons)  
Drill Line: 1-3/8" (34.9mm); **Offline stand building capability**  
Racking Capacity: 30,000' of 5" DP (9,144m of 127mm DP)  
27,250' of 5-1/2" DP (8,306m of 140mm DP)

## TOP DRIVE

Bentec TD-500-XT AC 500 Ton (456 Metric Tons)  
Max Speed: 220 rpm; Hoist Capacity: 1,000,000 lbs (454 Metric Tons)  
Continuous Drill Torque: 52,000 ft-lb (70,580 N-m)  
Torque Capacity: 75,000 ft-lb (101,700 N-m); Soft Torque on request  
Drill Pipe Range: 2-1/2" (63mm) to 8-1/2" (216mm)  
Max Drilling Fluid Pressure: **7,500 psi (35,000 kPa)**

## DRAWWORKS

IDS 1800 AC gear-driven 880,000 lbs (399 Metric Tons) w/ 12 lines  
Rated Power: **1,800 hp continuous; 2,250 hp intermittent**  
Input Power: 1,800 hp (1,342 KW) AC Traction motor  
Lebus Drum Groove: 1-3/8" (34.9mm)  
Parking / Emergency Brake: Wichita 336 SSB  
Fail-safe, spring-set brake; VFD Blower Control for quiet operations

## IRON ROUGHNECK

Bentec Iron Roughneck model IR-100-8-B  
Diameter Range: 2-7/8" (73 mm) to 9-3/4" (248 mm)  
Spin Speed: 100 RPM - max on 5" (127 mm) Drill Pipe  
Spin Torque: 3,000 ft-lbs (4,070 Nm); Reach: 8ft (2,438mm)  
Maximum Make-Up Torque: 100,000 ft-lbs (136,600 Nm)  
Maximum Break-Out Torque: 120,000 ft-lbs (162,700 Nm)

## CATWALK

North Rig C26 Hydraulic Catwalk w/ Skate and elevating trough  
Tubular max length: 45 feet (13.7m) Range III  
Max OD: 20" (508 mm) Max Weight: 10,000 lbs (4,536 kg)  
Max Pipe Rack Load: 30,000 lbs (13,608 kg) Cycle Time: 42 sec.

## ROTARY TABLE

National Type 375 37-1/2" (953 mm)  
Static Hookload 650 Tons (590 Metric Tons)  
Hydraulic drive for positioning tools only; Max Speed: 20 rpm

## GENERATOR PACKAGE

Four Kato 1,225 kW (1,642 hp) @ 1,200 rpm, 600V generators  
Coupled to Caterpillar 3512E diesel driver  
Engine Power 1,101 kW (1,476 hp)  
VFD Fan Control for quiet operation

## Sound attenuated buildings for low noise compliance areas

## DRIVE HOUSE BACKYARD

IDC Twin Vertical A/C units MCC Step-Up Transformer  
Generator Bays; Self-syncing generator controls

## DRIVE HOUSE RIG FLOOR

IDC Wall mount A/C unit, MCC Drawworks and Top Drive Controls  
Step-Down Transformer; Drill Cabin Power Control

## POWER SUPPLY FROM BACK YARD TO RIG FLOOR

IDC Safety Integration: Kirk Key System  
**ReelRig® Twin Reel Cable System with 250 ft (76 m)** of cable  
Twin lines lay in linebackers on the ground, no overhead bulk wiring

## DRILLER CABIN

IDC Controls: Four HMI touch screen / Joystick console panels  
Dual-Position running option for conventional or DS catwalk option  
Dual-Function console with height change adjust for Driller comfort

## BOP (NACE Standards)

CTI 13-5/8" (346 mm) x 5,000 psi (34,475 kPa) WP Spherical Annular  
CTI 13-5/8" (346 mm) x 10,000 psi (68,950 kPa) WP Hydraulic Double Ram  
CTI 13-5/8" (346 mm) x 10,000 psi (68,950 kPa) WP Hydraulic Single Ram  
CTI 13-5/8" (346 mm) x 10,000 psi (68,950 kPa) WP HEC Drilling Spool  
**BOP Handling System**-50 Tons; BOP transport skid w/ hyd actuated stand

*Note: Alternate BOP Sizes are available*

## CHOKES MANIFOLD

Total Oilfield Equipment  
4-1/16" (103 mm) x 10,000 psi (68,950 kPa) Manual Gate Valve  
4-1/16" (103 mm) x 10,000 psi (68,950 kPa) Hydraulic Choke: HCR Gate Valve  
4-1/16" (103 mm) x 10,000 psi (68,950 kPa) Check Valve  
Closing Unit: Meyer 6 station: 400-gallon tank; Class 1 Division 1 rating  
2 button operated safety system to open or close

## MUD PUMPS (3)

Three EmSCO Style 1600 Triplex Mud Pump; Manufacture: HH F1600  
Horsepower rating @ 120 SPM: 1,500 hp; Max Liner Size: 7" (178 mm)  
Stroke: 12" (305 mm); Input Power: (1) 1,500 hp Joliet AC motor  
Max Pressure Rating: **7,500 psi (51.7 MPa)**

## DRILLING CONTROL SYSTEM

- Programmed HMI for directional tool face
- Drawworks speed control adjustment
- On-board monitoring of instrumentation, engines and on-site alarm
- 360° pan-tilt camera system in the mast and cellar
- Drilling parameter control to drill off differential, WOB or both

## TUBULARS

Drill Pipe: Supplied as needed, *per availability*  
Drill Collars and Heavy Weight: Supplied as needed, *per availability*

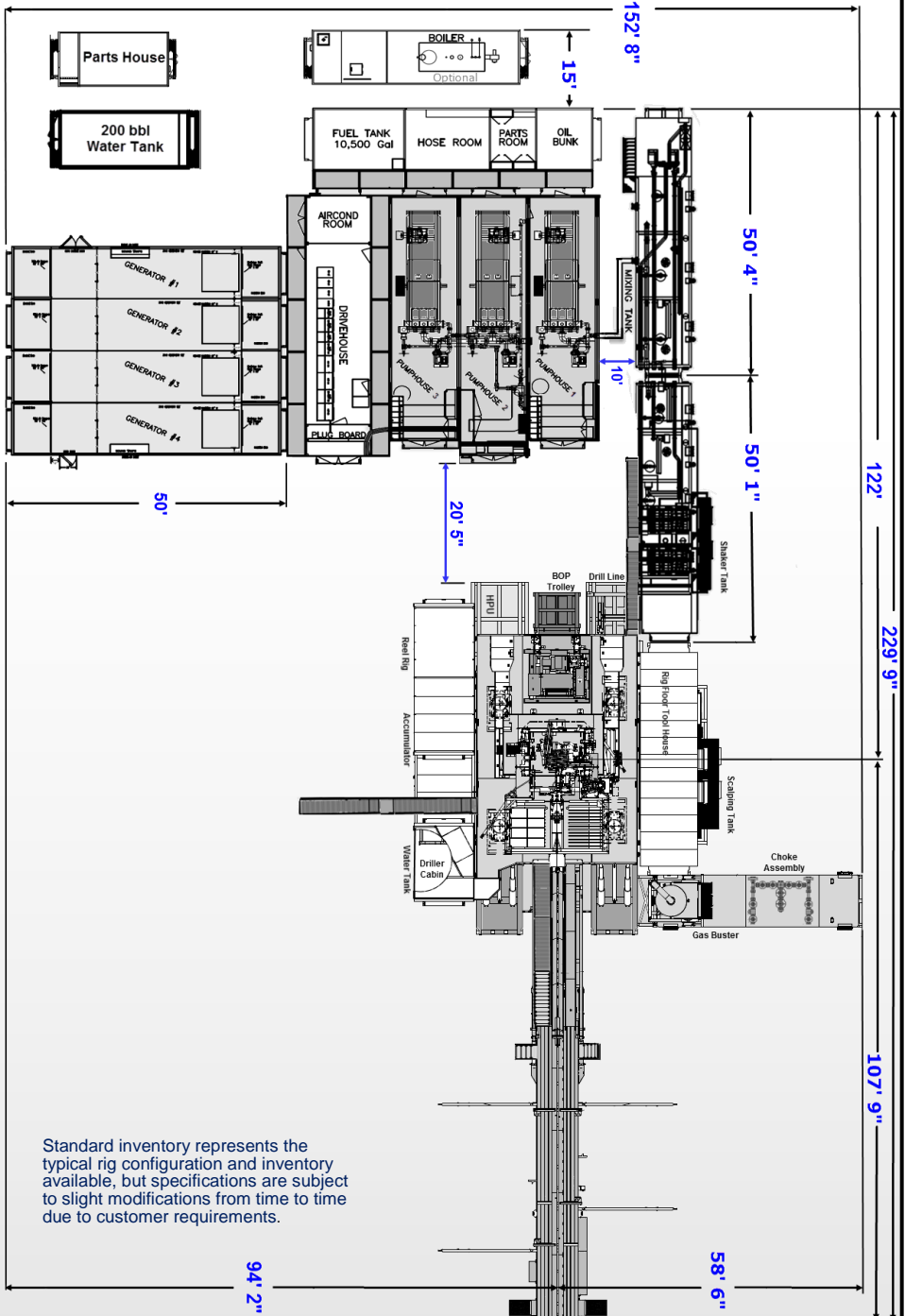

Standard inventory represents the typical rig configuration and inventory available, but specifications are subject to slight modifications from time to time due to customer requirements.

## MUD TANKS

Three Tanks w/ 1,156 bbls (184 m<sup>3</sup>) Total Active Volume

**SCALPING TRANSFER TANK** - Active Volume: 280 bbls (45 m<sup>3</sup>)  
Shale Shakers: (x2) MI SWACO Mongoose Dual Motion PRO Series  
(x1) Trip Tank 80 bbls (13 m<sup>3</sup>) Capacity; (x1) Trip Pump and (x1) Sand Trap  
(x1) Active compartment w/ agitator & mud gun; (x2) 60 hp mixing pumps

**SETTLING TANK** - Active Volume: 454 bbls (72 m<sup>3</sup>)  
(x2) compartments equipped with agitators and mud guns with  
(x2) MI SWACO Mongoose Dual Motion PRO series Shale Shakers

**SUCTION TANK** - Active Volume: 422 bbls (67 m<sup>3</sup>)  
(x2) active compartments and pill tank that can be used as active volume  
All compartments are equipped w/ agitators & mud guns; (x2) 60 hp mixing pumps  
(x1) hopper with ventilation system

## AUXILIARY BUILDINGS and EQUIPMENT

Rig Floor Tool House / Lubester; Parts House, HPU; Boiler - (x1) 125 hp  
Pipe Racks (x2) sets of pipe racks and (x2) sets of finger racks  
Rig Manager Trailer - One 14' x 44' (4.3m x 13.4m) Skid mounted  
Fuel Tank - (x1) 10,500 Gallons (39,750 liters) with (x2) 5 hp fuel pumps  
Water Tanks - (x2) 200 bbls (24m<sup>3</sup>) Tanks with dual 10 hp water pumps

All ratings quoted herein are manufacture specifications. AKITA's normal operating parameters are 90% of manufactures mast rating and 80% of mud pump manufacturer pressure rating. Operation of rig equipment beyond these parameters requires approval from AKITA field office management.